

## STANDARD STEEL FRAMES

### SPECIFICATIONS

#### MESKER STANDARD STEEL FRAMES

1. Frames shall be manufactured by Mesker Door Incorporated and designated as F-416 (16 GA) or F-414 (14 GA) for 1 3/4" doors, F-412 for Bullet Resistant Frames and F-816 (16 GA) for 1 3/8" doors.
2. Frames shall be fabricated from cold rolled or A60 galvanized steel.
3. Frames shall be furnished knocked down. Mitered corners shall have a strong four tab interlocking system to maintain tight fineline miters.
4. Frames for 1 3/4" doors shall be prepared for a 4 1/2" x 4 1/2" standard or heavy weight template hinges and ANSI 115.1 universal strike.
5. Frames for 1 3/8" doors shall be prepared for 3 1/2" x 3 1/2" standard weight template hinges and ANSI 115.3 cylindrical strike.
6. Frames shall be adequately reinforced for all hardware.
7. Strike and hinge reinforcements shall be protected by plaster guards.
8. Frames shall be supplied with 1 sill anchor.
9. Frames shall be furnished with rubber mutes, three per strike jamb.
10. Frames shall receive 1 coat of baked-on rust inhibitive gray primer.
11. For installation instructions see ANSI A250.11-2001 and DS-201-5.



# TECHNICAL DATA SHEET

**DS-201-2**

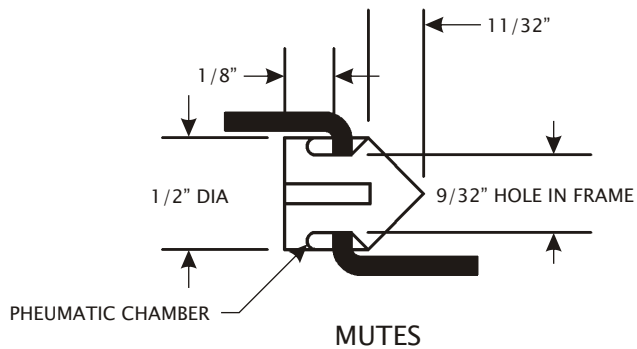

TO INSTALL IN FIELD INSERT BLUNT END OF 3/32" DIAMETER WIRE OR TOOL INTO THE HOLE IN CENTER OF THE MUTE. MOISTEN CONE PORTIONS AND INSERT INTO 9/32" HOLE IN STOP OF FRAME, PUSH SLOWLY WITH A CIRCULAR MOTION TO ELONGATE CONICAL PORTION SUFFICIENTLY TO SET MUTE IN PLACE.

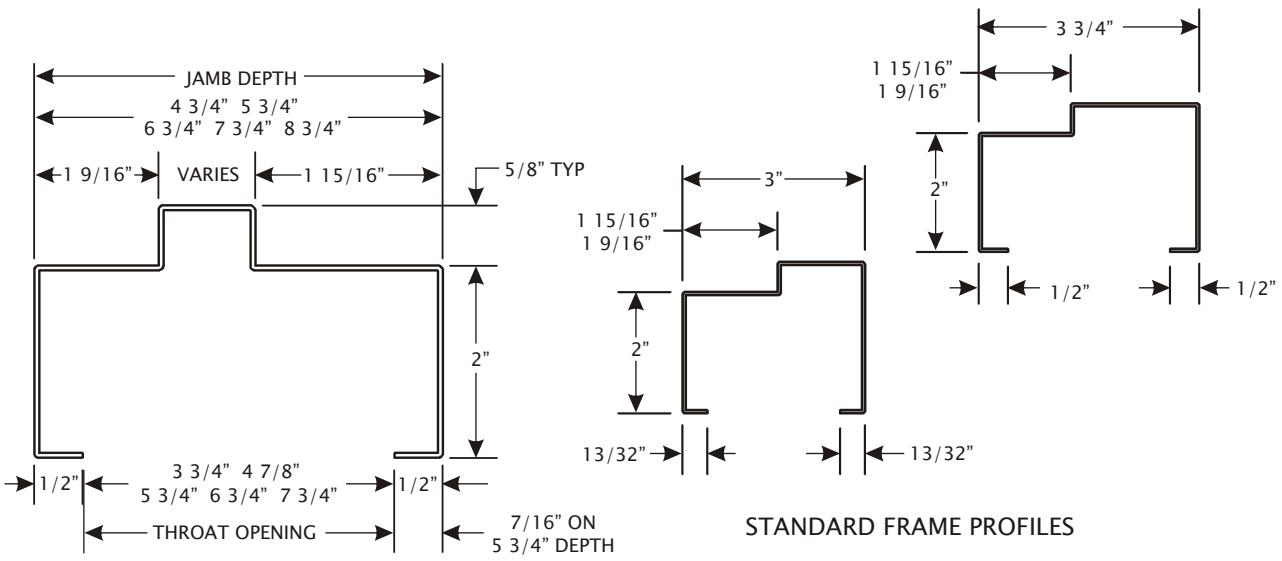

STANDARD FRAME PROFILES

FINISHED OPENING HEIGHT	FINISHED OPENING WIDTH		FRAME DIMENSIONS	
	SINGLE	DOUBLE	JAMB DEPTH	THROAT OPENING
6'-8"	2'-0"	4'-0"	3"	2 3/16"
	2'-4"	4'-8"		
7'-0"	2'-6"	5'-0"	3 3/4"	2 3/4"
	2'-8"	5'-4"	4 3/4"	3 3/4"
7'-2"	3'-0"	6'-0"	5 3/4"	4 7/8"
	3'-6"	7'-0"	7 3/4"	6 3/4"
8'-0"	3'-8"	7'-4"	8 3/4"	7 3/4"
	4'-0"	8'-0"		

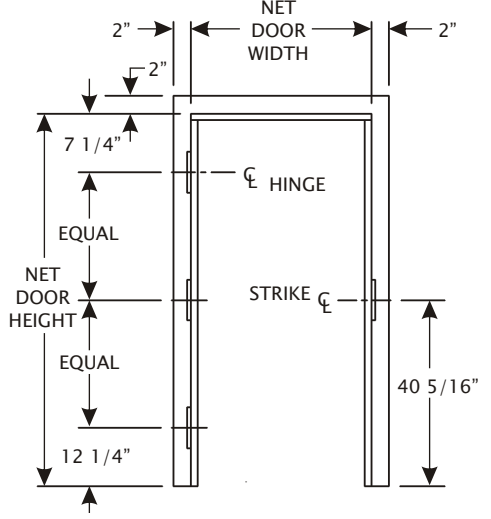

January 2007



**MESKER**  
www.meskerdoor.com  
256-851-6670, 256-852-5846

# TECHNICAL DATA SHEET

**DS-201-3**

HINGE PREPARATION WILL TAKE 4 1/2" HIGH TEMPLATE HINGES ONLY STANDARD OR HEAVY WEIGHT, NON-TEMPLATE HINGES CANNOT BE USED

#20 GAUGE PLASTER GUARD PROJECTION WELDED TO HINGE REINFORCEMENT

3/16" HINGE REINFORCEMENT PROJECTION WELDED TO FRAME.

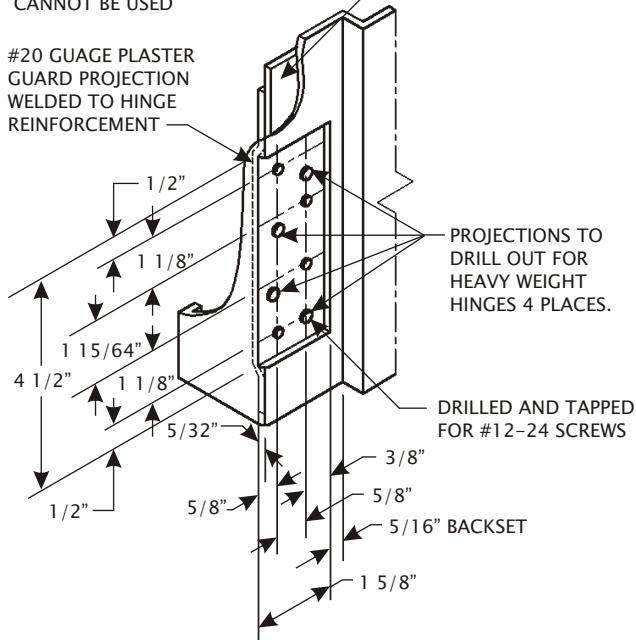

STANDARD 4 1/2" HINGE MORTISE FOR 1 3/4" FRAMES

HINGE PREPARATION WILL TAKE 3 1/2" X 3 1/2" TEMPLATE HINGES OR NON-TEMPLATE (S.D.I.) HINGES

#10 GAUGE HINGE REINFORCEMENT PROJECTION WELDED TO FRAME

#20 GAUGE PLASTER GUARD PROJECTION WELDED TO HINGE REINFORCEMENT

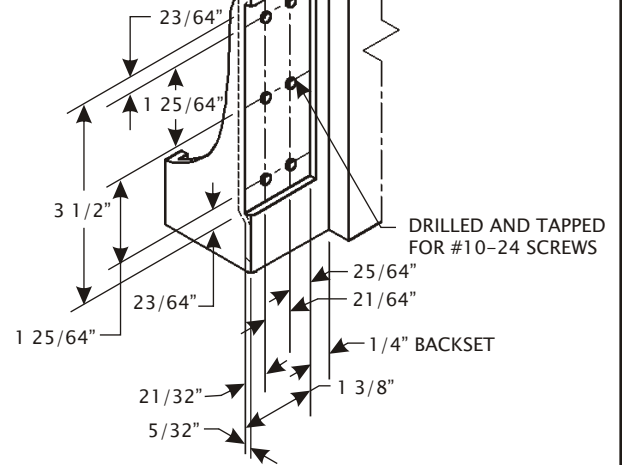

STANDARD 3 1/2" HINGE MORTISE FOR 1 3/8" FRAMES

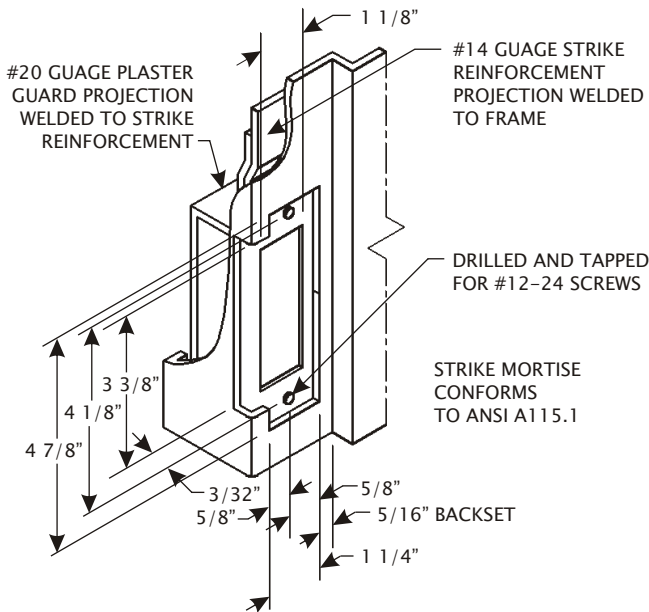

"U" STRIKE MORTISE

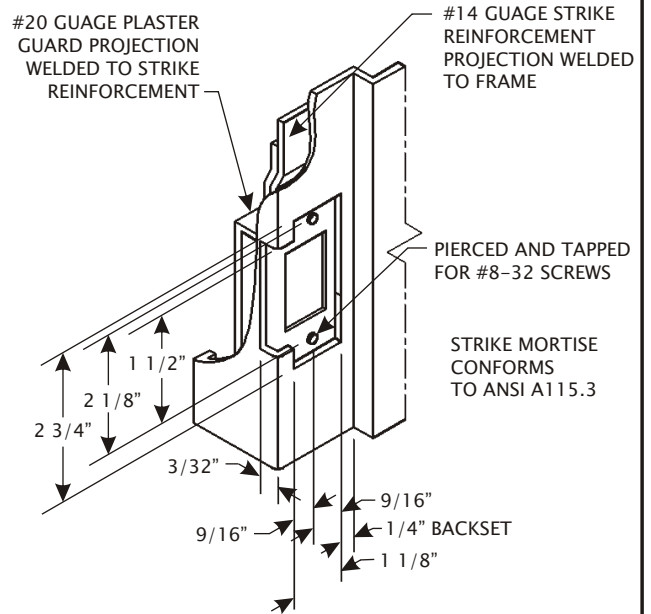

"C" STRIKE MORTISE

January 2007



**MESKER**

www.meskerdoor.com  
256-851-6670, 256-852-5846

# TECHNICAL DATA SHEET

**DS-201-4**

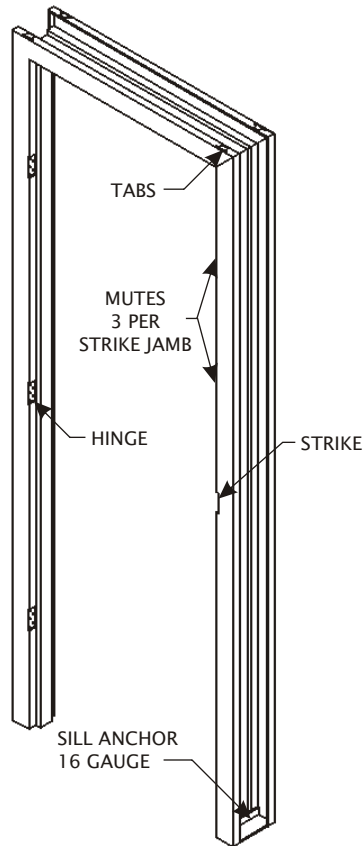

## GENERAL INFORMATION

### STRIKE PREPARATIONS

Frames are prepared for 4 7/8" high universal strike (ANSI 115.1) specify "U" and 2 3/4" high cylindrical strike (ANSI 115.3) specify "C".

### HINGE PREPARATIONS

Frames for 1 3/4" doors are prepared for 4 1/2" x 4 1/2" standard or heavy weight template hinges. 1 1/2" pair on doors up to 7'-2" in height and 2 pair on 7'-10" and 8'-0".

Frames for 1 3/8" doors are prepared for 3 1/2" x 3 1/2" standard weight template hinges. 1 pair on 6'-8" doors and 1 1/2" pair on 7'-0" and 7'-2" doors. U/L labeled frames have 1 1/2" pair on all sizes.

### ANCHORS

Anchors must be specified to correspond with wall condition. Details are shown on the following data sheets:

- Wire Anchor - DS 246
- Masonry Tee Anchor - DS 242
- Wood and Steel Stud Anchor - DS 243
- U/L Labeled Masonry Anchor - DS 241
- Existing Wall Anchor - DS 245

### SILL ANCHORS

Each jamb is supplied with 1-16 gauge sill anchor.

### MUTES

Each frame is furnished with rubber mutes. Three per strike jamb.

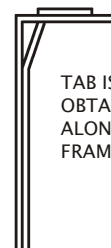
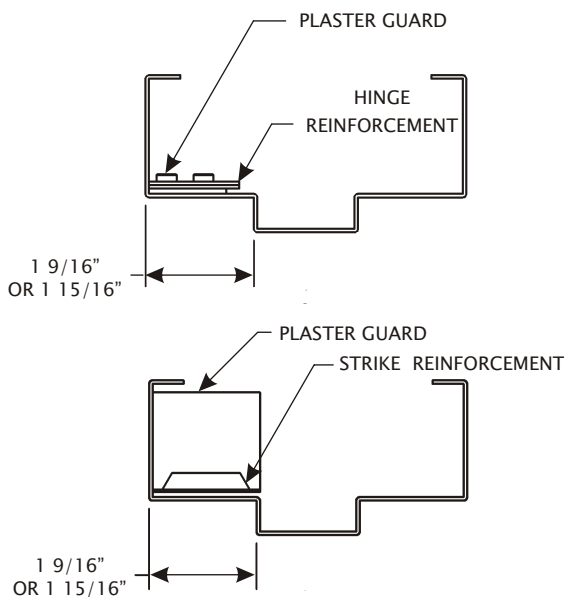

SECTION THRU TAB

TAB IS OFFSET TO OBTAIN SMOOTH BEND ALONG TOP OF FRAME HEAD.

January 2007



**MESKER**

www.meskerdoor.com  
256-851-6670, 256-852-5846

## F-SERIES ASSEMBLY INSTRUCTION

1. Slide header over jamb corner tabs, insert into slots.
2. Bend tabs on jamb rabbets out per illustration. (NOTE: Bending tabs in will increase door opening dimension.)
3. Bend corner tabs in per illustration.

